

Professional Series

Key Features:

- ▶ 25 mm (1 in) horn throat diameter
- ▶ Alternate 1 3/8" - 18 screw mounting
- ▶ 70 watts continuous program at 800 Hz
- ▶ 100 watts continuous program above 1.2 kHz
- ▶ 44 mm (1 3/4 in) pure titanium diaphragm
- ▶ Patented diamond-pattern diaphragm suspension
- ▶ 44 mm (1 3/4 in) edgewound aluminum ribbon wire voice coil
- ▶ Copper-plated pole piece for reduced inductance and increased high-frequency output

The model 2426H is a professional quality high frequency compression driver which incorporates JBL's titanium diamond diaphragm. This titanium diamond structure combines the ruggedness of phenolic and composite-type diaphragms with the outstanding frequency response of fragile aluminum and exotic metal diaphragms.

JBL's exclusive suspension¹, consisting of a three-dimensional diamond pattern, reduces bending stresses in the diaphragm support structure. The depth of the diamond pattern is closely controlled to provide predictable frequencies for the 2nd and 3rd normal resonance modes and for the basic suspension resonance.

The mathematically determined phasing plug consists of concentric exponential horns to minimize phase cancellations. Phasing plug, throat exit tube and diaphragm assemblies are identical to the previous model.

All cast parts and tolerances are held to the same levels traditionally associated with JBL designs. Additionally the press-fit assembly and interlocking parts assure greater resistance to the mechanical shock. Diaphragm assemblies are rim centered rather than pin mounted, for instant interchangeability and ease of field service. Mounting is provided for standard 25 mm (1 in) three bolt pattern. The front snout may be removed (unscrewed) to allow standard 1 3/8" - 18 screw mounting. Through holes for

¹U. S. Patent 4,324,312



Specifications:

Throat Diameter:	25 mm (1 in)
Nominal Impedance:	2426H - 8 ohms 2426J - 16 ohms
Minimum Impedance:	5 ohms (H), 9 ohms (J) @ 5 kHz
D.C. Resistance:	3.3 ohms (H), 6.5 ohms (J) ± 10% @ 25°C
Power Capacity:	70 W continuous program above 800 Hz 100 W continuous Program above 1.2 kHz
Sensitivity:	107 dB SPL, 1 W @ 1 m, JBL 2344A horn ² 110 dB SPL, 1 W @ 1 m, JBL 2370A horn ² 117 dB SPL, 1 mW on plane wave tubes
Nominal Efficiency:	25% (800 Hz to 2.5 kHz)
Frequency Range:	500 Hz to 20 kHz
Recommended Crossover:	800 Hz or higher, 12 dB/octave slope minimum
Diaphragm:	0.05 mm (0.002 in) pure titanium
Voice Coil Diameter:	44 mm (1 3/4 in)
Voice Coil Material:	Edgewound aluminum ribbon
Flux Density:	1.8 T (18,000 gauss)
BL Factor:	6.3 N/A(H) 9.3 N/A (J)
Positive voltage to black terminal gives diaphragm motion toward phasing plug	
MOUNTING INFORMATION:	
Mounting:	Three 1/4-20 threaded holes, 120° apart on 57.2 mm (2 1/4 in) diameter Front snout may be removed (unscrewed) to expose standard 1 3/8 in -18 screw threads
Dimensions:	149 mm (5 7/8 in) diameter 104 mm (4 1/8 in) depth
Net Weight:	4.3 kg (9 1/2 lb)

²Continuous program is defined as 3 dB greater than continuous pink noise and is a conservative expression of the transducer's ability to handle normal speech and music program material. Continuous pink noise power ratings are rested with pink noise input having a 6 dB crest factor for two hours duration, per AES standard.

³Sensitivity measured on-axis in the far field with 2.83 V rms at 8 ohms or 4.0 V rms at 16 ohms and referred to 1 meter distance calculated by inverse square law. Listed sound pressure level (SPL re 20 uPa) represents an average from 1 kHz to 4 kHz.

⁴As specified by recognized standards organizations, JBL plane wave tube measurements represent the SPL in a 25 mm diameter terminated tube, using a 1 mW input signal (0.126 V rms into 16 ohms, 0.089 V rms into 8 ohms) swept from 800 Hz to 2.5 kHz. The sensitivity with a 1 W input would be 30 dB greater.

⁵A 2426 can be used to 500 Hz; however, power capacity will be reduced to 20 W continuous program in the region between 500 Hz and 800 Hz.

JBL continually engages in research related to product improvement. New materials, production methods, and design refinements are introduced into existing products without notice as a routine expression of that philosophy. For this reason, any current JBL product may differ in some respect from its published description, but will always equal or exceed the original design specifications unless otherwise stated.

▶ 2426H/J Compression Driver

external attachment points are also provided. A machined ring of copper surrounds the pole piece to counteract the inductance of the voice coil at high frequencies. After manufacture, the frequency response of each driver is tested for conformity to rigid performance standards.

The 2426H is offered in an 8 ohm impedance, and the otherwise identical 2426J is offered in a 16 ohm impedance.

Architectural Specifications:

The compression driver shall consist of a ferrite magnetic structure. All magnetic assembly parts shall be machined from cast or extruded billet stock. The phasing plug shall be assembled of concentric horns to minimize phase cancellations, and it shall be further coupled to a tapered throat. Driver mounting shall consist of a removable snout incorporating standard 25mm (1 in) three bolt pattern and fitted with three external attachment points. The snout shall be removable to allow the use of 1 3/8" - 18 screw-thread attachment.

The diaphragm shall be 0.05 mm (0.002 in) pure titanium pneumatically drawn to shape. High frequency response shall be controlled through the use of a three-dimensional suspension structure. The voice coil shall be edgewound aluminum ribbon of not less than 44 mm (1 3/4 in) in diameter, operating in a magnetic field of not less than 1.8 tesla (18,000 gauss). An impedance controlling ring shall be affixed to the pole piece in order to increase efficiency at high frequencies.

Performance specifications of a typical production unit shall be as follows: Measured sensitivity with a 1 m W input on a 25 mm (1 in) terminated tube, averaged from 800 Hz to 2.5 kHz, shall be at least 117 dB SPL. Measured sensitivity with a 1 W input at 1 m distance on-axis from the mouth of a horn with a Q of 6.3, averaged in the 2 kHz octave band, shall be at least 110 dB SPL. As an indication of electromechanical conversion efficiency, the Bl factor shall be at least 6.3 (9.3) newtons per ampere. Frequency response, measured on a terminated tube, shall be flat within ± 1 dB from 800 Hz to 3.3 kHz, with a 6 dB/octave rolloff above that point. Nominal impedance shall be 8 [16] ohms and power capacity shall be at least 70 watts normal speech or music program material.

The compression driver shall be JBL Model 2426 H [J]. Other drivers will be considered for equivalency provided that submitted data from a recognized independent test laboratory verify that the above performance specifications are met.

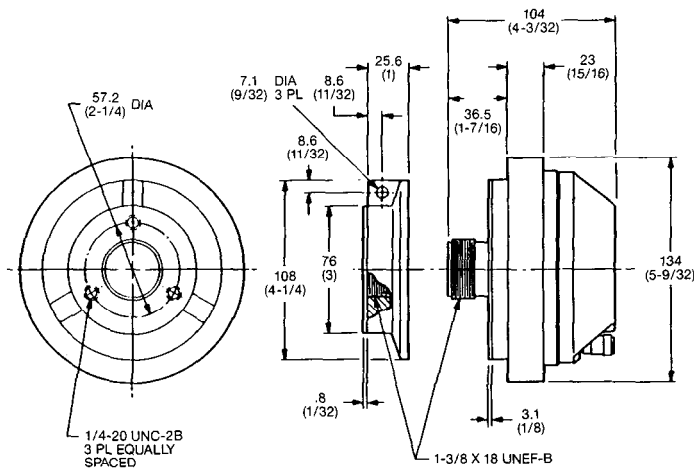

NOTE: DIMENSIONS IN () ARE IN INCHES.

Response on JBL 2370 Flat-Front Bi-Radial® Horn

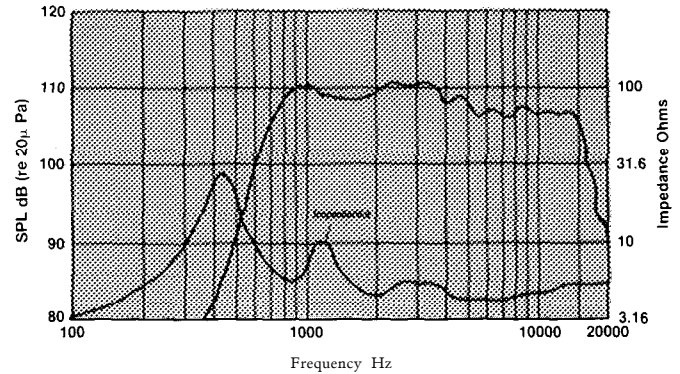

Frequency response of the 2426H coupled to a JBL 2370 Flat-Front Bi-Radial horn, measured on-axis at a distance of 1 meter with a 1 watt (2.83 V RMS) input in a reflection-free environment, with impedance vs. frequency curve. The increased high-frequency output is due to the horn design's increasing directivity in the vertical plane.

Response on Plane-Wave Terminated Tube

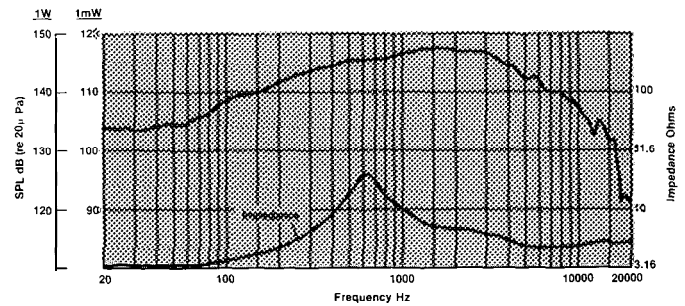

Frequency response and impedance modulus of Model 2426H coupled to a 25 mm (1 in) diameter terminated plane-wave tube. This is the power response of the transducer, and is the frequency response that will be obtained on a true full-bandwidth constant-directivity horn design, such as JBL's 2360 series of Constant Coverage Bi-Radial Horns.



JBL Professional
8500 Balboa Boulevard, PO. Box 2200
Northridge, California 91329 U.S.A.

A Harman International Company

SS2426
10/94 10M
P1055